

Techtop Industries Nameplate and Performance Data

NAMEPLATE DATA		
	60 Hz.	50 Hz.
Horsepower	2.0	-
Frame Size	145T	
Speed, RPM	1740	-
Voltage	1 Phase US	-
# Phase	1	
Full Load Amps	17.3/10.4-8.65	-
Power Factor	0.92	-
Nominal Efficiency	81.5	-
3/4 Load Efficiency	-	-
Service Factor	1.15	-
Duty	Cont. / S1	
FL Temp Rise °C	73.7	-
Enclosure	TEFC	
Ambient Temp °C	40	
KVA Code	H	-
FL Amps. @ 208 V	10.4	-
Insulation Class	F	
NEMA Design	L	
Weight	53.0	
DE Bearing	6205-2RZ	
NDE Bearing	6203-2RZ	
dB No-Load	-	
Rotor Wk ² , Lb-Ft ²	-	
Start Capacitor		
Start Capacitor V	165	
Run Capacitor		
Run Capacitor V	250	
Number of Leads	7	
Connection	-	
Coil Resistance	0.0	

Motor Model:	RD1-RS-TF-145T-4-B-C-2
---------------------	-------------------------------

Performance Load Values:

% Load	Horsepower	Current, Amps	Input power, Kilowatts	Speed, RPM	Efficiency	PF
0	-	-	-	-	-	-
25	-	-	-	-	-	-
50	-	-	-	-	-	-
75	-	-	-	-	-	-
100	-	-	-	-	-	-
125	-	-	-	-	-	-
150	-	-	-	-	-	-
SF	-	-	-	-	-	-

	Torque, Lb-Ft	% Full Load Torque	Speed, RPM	Current Amps.
Locked Rotor Torque	-	-	-	-
Pull Up Torque	-	-	-	-
Breakdown Torque	-	-	-	-
Full Load	-	100.0	-	-

Speed Torque Curve

Please contact Techtop for image.

Dimensional Drawing

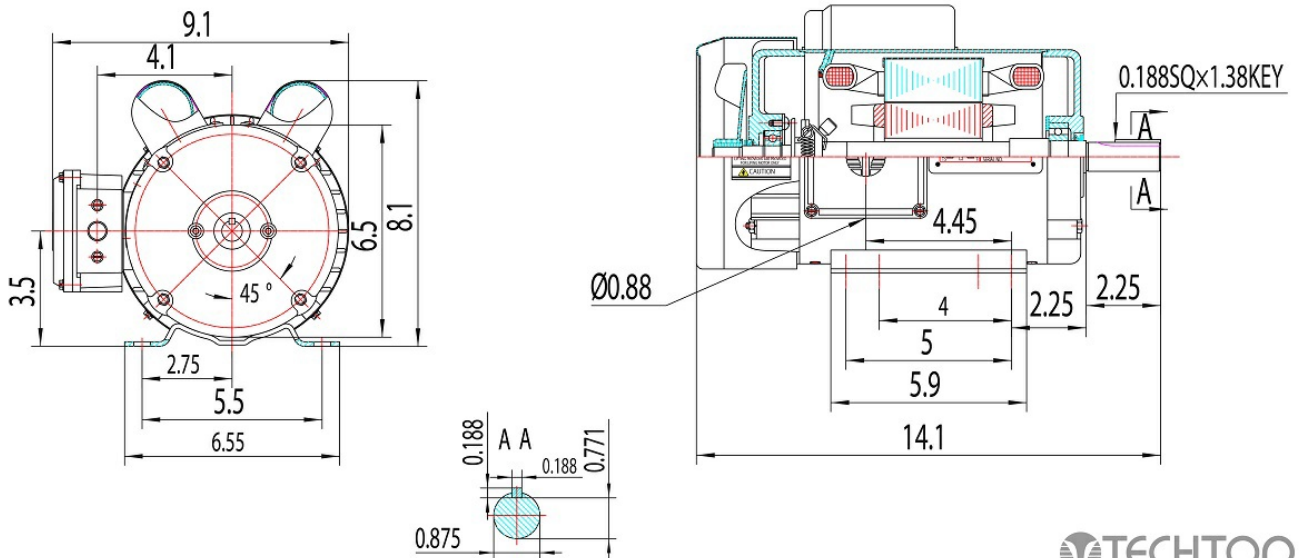

Dimensions are for reference only. Allowance should be made for minor deviations in non standard specified properties.

3D Image Link: Not available for this motor