

Techtop Industries Nameplate and Performance Data

NAMEPLATE DATA		
	60 Hz.	50 Hz.
Horsepower	75.0	75.0
Frame Size	365T	
Speed, RPM	1775	-
Voltage	3 Phase US (575V)	-
# Phase	3	
Full Load Amps	66.91763318	-
Power Factor	0.87	-
Nominal Efficiency	95.4	-
3/4 Load Efficiency	-	-
Service Factor	1.15	1.0
Duty	Cont. / S1	
FL Temp Rise °C	62.0	-
Enclosure	TEFC	
Ambient Temp °C	40	
KVA Code	L	-
FL Amps. @ 208 V	-	-
Insulation Class	F	
NEMA Design	A	
Weight	873.18	
DE Bearing	6313C3	
NDE Bearing	6313C3	
dB No-Load	-	
Rotor Wk ² , Lb-Ft ²	-	
Start Capacitor	-	
Start Capacitor V	-	
Run Capacitor	-	
Run Capacitor V	-	
Number of Leads	6	
Connection	?	
Coil Resistance	-	

Motor Model:	GR3-CI-TF-365T-4-BR-F-75
---------------------	---------------------------------

Performance Load Values:

% Load	Horsepower	Current, Amps	Input power, Kilowatts	Speed, RPM	Efficiency	PF
0	37.5	27.82	-	-	-	-
25	37.5	32.3	15.16	1795.3	92.0	0.59
50	37.5	47.4	29.4	1790.9	94.91	0.78
75	56.25	64.34	43.82	1786.2	95.51	0.85
100	75.0	82.84	58.45	1781.2	95.47	0.89
125	37.5	102.61	73.31	1775.9	95.15	0.9
150	37.5	123.38	88.41	1770.2	94.67	0.9
SF	-	-	-	-	-	-

	Torque, Lb-Ft	% Full Load Torque	Speed, RPM	Current Amps.
Locked Rotor Torque	734.712	328.0	-	1001.0
Pull Up Torque	369.596	165.0	-	-
Breakdown Torque	665.273	297.0	-	-
Full Load	223.998	100.0	1781.2	82.84

Speed Torque Curve

Please contact Techtop for image.

Dimensional Drawing

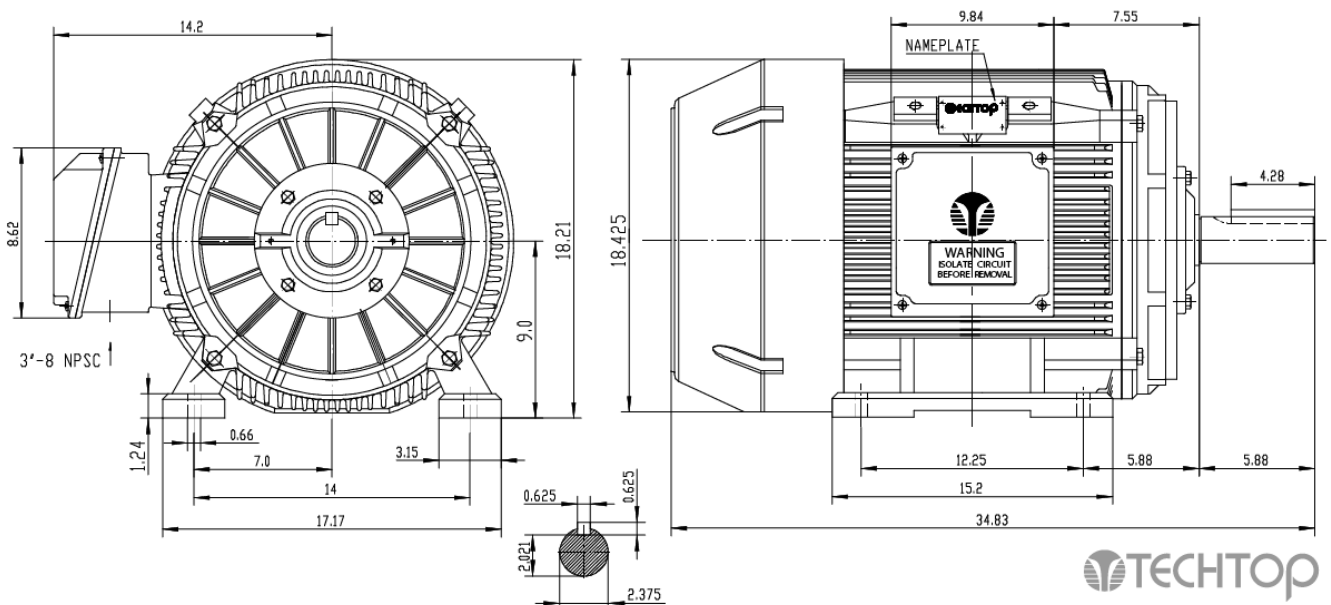

Dimensions are for reference only. Allowance should be made for minor deviations in non standard specified properties.

3D Image Link: Not available for this motor

