



NEMA Premium

NEMA

MOTOR MODEL:	GR3-CI-TF-143T-2-B-D-1.5
FACTORY TYPE:	TXC

Premium NEMA Cast Iron, TEFC

ELECTRICAL DATA		
	60 Hz	50 Hz
Horsepower	1.5	1.5
Speed, RPM	3450	2850
Voltage	230/460	190/380
# Phase	3	
Full Load Amps	2-Apr	5.2/2.6
Power Factor	0.83	-
Nominal Efficiency	84.0	81.0
3/4 Load Efficiency	-	-
Service Factor	1.25	1.0
KVA Code	K	J
FL Amps. @ 208 V	4.42308	-
Locked Rotor Current	18.2307	-
Start Capacitor	-	
Start Capacitor V	-	
Run Capacitor	-	
Run Capacitor V	-	
Number of Leads	9	
Connection	YY/Y	
Coil Resistance	-	
Date Code	-	
Load	Efficiency %	P.F.
50%	83.17	0.58
75%	85.78	0.72
100%	86.23	0.8
FULL LOAD TEMPERATURE RISE		
FL Temp Rise °C	-	-
3D Image Link		
GR3-CI-TF-143T-2-B-D-1.5		

GENERAL DATA		
Frame Size	143T	
Frame Enclosure	TEFC	
Mounting	Rigid	
Insulation Class	F	
Duty	Cont. / S1	
NEMA Design	A	
Frame Material	Cast Iron	
Ingress Protection	55	
Tropicalization	true	
Cable Entry	1-NPT 3/4"	
Feet Removable	true	
Double Drilled	-	
Paint Color	Graphite Gray	
Paint RAL	7024	
Weight lb	41.895	
MECHANICAL DATA		
DE Bearing	6205ZZ	
NDE Bearing	6205ZZ	
dB No-Load	-	
Rotor Wk ² , Lb-Ft ²	-	
Comp Ring (wavey washer)	NDE	
TORQUE VALUES		
	Torque lb-ft	% FLT
Locked Rotor Torque	7.18504	328.0
Pull-Up Torque	4.99448	228.0
Breakdown Torque	8.34603	381.0
Full Load Torque	2.19056	100.0
SITE CONDITIONS		
Ambient Temp °C	40	
Altitude Above Sea Level m	1000	

*This report valid for above Date Code and newer models, please contact Techtop for more info.



NEMA Premium

MOTOR MODEL:	GR3-CI-TF-143T-2-B-D-1.5
FACTORY TYPE:	TXC

NEMA

Premium NEMA Cast Iron, TEFC

Non Sinusoidal (VFD) Output 1.5HP, 3450 RPM

Torque Speed (T-n) Curve

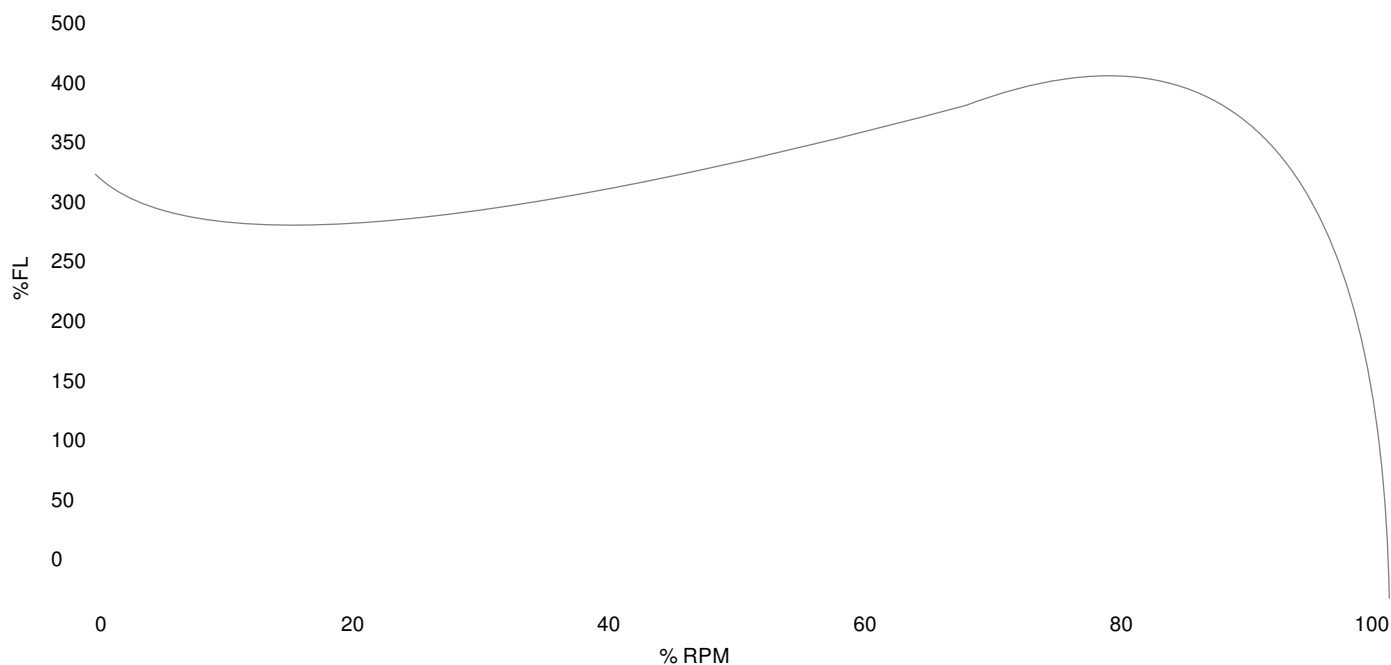

Performance Load Values, High Voltage, 60Hz

Torque Values	Torque lb-ft	% FLT	Performance Values	
Locked Rotor Torque	7.18504	328.0	Start Configuration	-
Pull-Up Torque	4.99448	228.0	Starting Current (A)	-
Breakdown Torque	8.34603	381.0	No-Load Current (A)	-
Full Load	2.19056	100.0	No-Load Power Factor	-

% Load	Horsepower	Current, Amps	Input power, Kilowatts	Speed, RPM	Efficiency	PF
0	-	1.22	-	-	-	-
25	0.375	1.27	372.11	3576.3	73.9	0.37
50	0.75	1.43	661.32	3556.2	83.17	0.58
75	1.125	1.69	961.82	3533.7	85.78	0.72
100	1.5	2.01	1275.7	3508.7	86.23	0.8
125	1.875	2.39	1605.2	3481.3	85.66	0.84

Techtop Industries
 2815 Colonnades Court
 Peachtree Corners, GA 30071
 Tel: 678-436-5540
 E-Mail: info@techttopind.com