



NEMA Premium

NEMA

MOTOR MODEL:	GR3-AL-TF-182T-6-B-F-1.5
FACTORY TYPE:	TXA

Premium NEMA Cast Aluminum, TEFC

ELECTRICAL DATA		
	60 Hz	50 Hz
Horsepower	1.5	1.5
Speed, RPM	1175	-
Voltage	575	-
# Phase	3	
Full Load Amps	1.86	-
Power Factor	0.68	-
Nominal Efficiency	87.5	-
3/4 Load Efficiency	-	-
Service Factor	1.25	-
KVA Code	L	-
FL Amps. @ 208 V	-	-
LRC @ 60Hz HV	-	-
Start Capacitor	-	
Start Capacitor V	-	
Run Capacitor	-	
Run Capacitor V	-	
Number of Leads	3	
Connection	Y	
Coil Resistance	-	
Date Code	-	
Load	Efficiency %	P.F.
50%	-	-
75%	-	-
100%	-	-
FULL LOAD TEMPERATURE RISE		
FL Temp Rise °C	-	-
3D Image Link		
GR3-AL-TF-182T-6-B-F-1.5		

GENERAL DATA			
Frame Size	182T		
Frame Enclosure	TEFC		
Mounting	Rigid		
Insulation Class	F		
Duty	Cont. / S1		
NEMA Design	B		
Frame Material	Cast Aluminum		
Ingress Protection	55		
Tropicalization	true		
Cable Entry	1-NPT 3/4"		
Feet Removable	true		
Double Drilled	-		
Paint Color	Graphite Gray		
Paint RAL	7024		
Weight lb	39.5		
MECHANICAL DATA			
DE Bearing	6306ZZ		
NDE Bearing	6206ZZ		
dB No-Load	-		
Rotor Wk ² , Lb-Ft ²	-		
Comp Ring (wavey washer)	NDE		
TORQUE VALUES		Torque lb-ft	% FLT
Locked Rotor Torque	-	-	
Pull-Up Torque	-	-	
Breakdown Torque	-	-	
Full Load Torque	-	-	
SITE CONDITIONS			
Ambient Temp °C	40		
Altitude Above Sea Level m	1000		

*This report valid for above Date Code and newer models, please contact Techttop for more info.



NEMA Premium

NEMA

MOTOR MODEL:	GR3-AL-TF-182T-6-B-F-1.5
FACTORY TYPE:	TXA

Premium NEMA Cast Aluminum, TEFC

Torque Speed (T-n) Curve

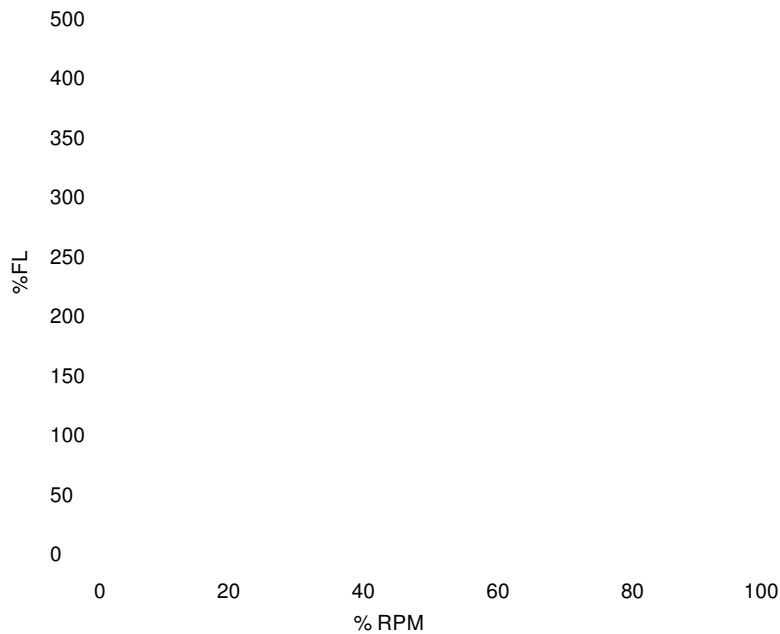

Performance Load Values, High Voltage, 60Hz

Torque Values	Torque lb-ft	% FLT	Performance Values
Locked Rotor Torque	-	-	Start Configuration
Pull-Up Torque	-	-	Starting Current (A)
Breakdown Torque	-	-	No-Load Current (A)
Full Load	-	-	No-Load Power Factor

% Load	Horsepower	Current, Amps	Input power, Kilowatts	Speed, RPM	Efficiency	PF
0	-	-	-	-	-	-
25	-	-	-	-	-	-
50	-	-	-	-	-	-
75	-	-	-	-	-	-
100	-	-	-	-	-	-
125	-	-	-	-	-	-