



NEMA Premium

**NEMA**

<b>MOTOR MODEL:</b>	GR3-AL-TF-145TC-2-B-D-2
<b>FACTORY TYPE:</b>	TXA

Premium NEMA Cast Aluminum, TEFC

ELECTRICAL DATA		
	60 Hz	50 Hz
Horsepower	2.0	2.0
Speed, RPM	3500	2880
Voltage	230/460	190/380
# Phase	3	
Full Load Amps	5.18/2.59	6.16/3.08
Power Factor	0.85	-
Nominal Efficiency	85.5	83.8
3/4 Load Efficiency	-	-
Service Factor	1.25	1.0
KVA Code	L	H
FL Amps. @ 208 V	5.58	-
LRC @ 60Hz HV	23.2974	-
Start Capacitor	-	
Start Capacitor V	-	
Run Capacitor	-	
Run Capacitor V	-	
Number of Leads	9	
Connection	YY/Y	
Coil Resistance	-	
Date Code	-	
Load	Efficiency %	P.F.
50%	84.53	0.67
75%	86.37	0.79
100%	86.27	0.85
FULL LOAD TEMPERATURE RISE		
FL Temp Rise °C	39.7	39.0
3D Image Link		
Not available for this motor		

GENERAL DATA		
Frame Size	145TC	
Frame Enclosure	TEFC	
Mounting	Rigid/C-Flange	
Insulation Class	F	
Duty	Cont. / S1	
NEMA Design	B	
Frame Material	Cast Aluminum	
Ingress Protection	55	
Tropicalization	true	
Cable Entry	1-NPT 3/4"	
Feet Removable	true	
Double Drilled	-	
Paint Color	Graphite Gray	
Paint RAL	7024	
Weight lb	29.5	
MECHANICAL DATA		
DE Bearing	6205ZZ	
NDE Bearing	6205ZZ	
dB No-Load	-	
Rotor Wk <sup>2</sup> , Lb-Ft <sup>2</sup>	-	
Comp Ring (wavy washer)	-	
TORQUE VALUES		% FLT
Locked Rotor Torque	8.91226	294.0
Pull-Up Torque	6.12339	202.0
Breakdown Torque	10.0642	332.0
Full Load Torque	3.03138	100.0
SITE CONDITIONS		
Ambient Temp °C	40	
Altitude Above Sea Level m	1000	

\*This report valid for above Date Code and newer models, please contact Techtop for more info.

Techtop Industries  
 2815 Colonnades Court  
 Peachtree Corners, GA 30071  
 Tel: 678-436-5540  
 E-Mail: info@techttopind.com



NEMA Premium

**NEMA**

<b>MOTOR MODEL:</b>	GR3-AL-TF-145TC-2-B-D-2
<b>FACTORY TYPE:</b>	TXA

Premium NEMA Cast Aluminum, TEFC

Torque Speed (T-n) Curve

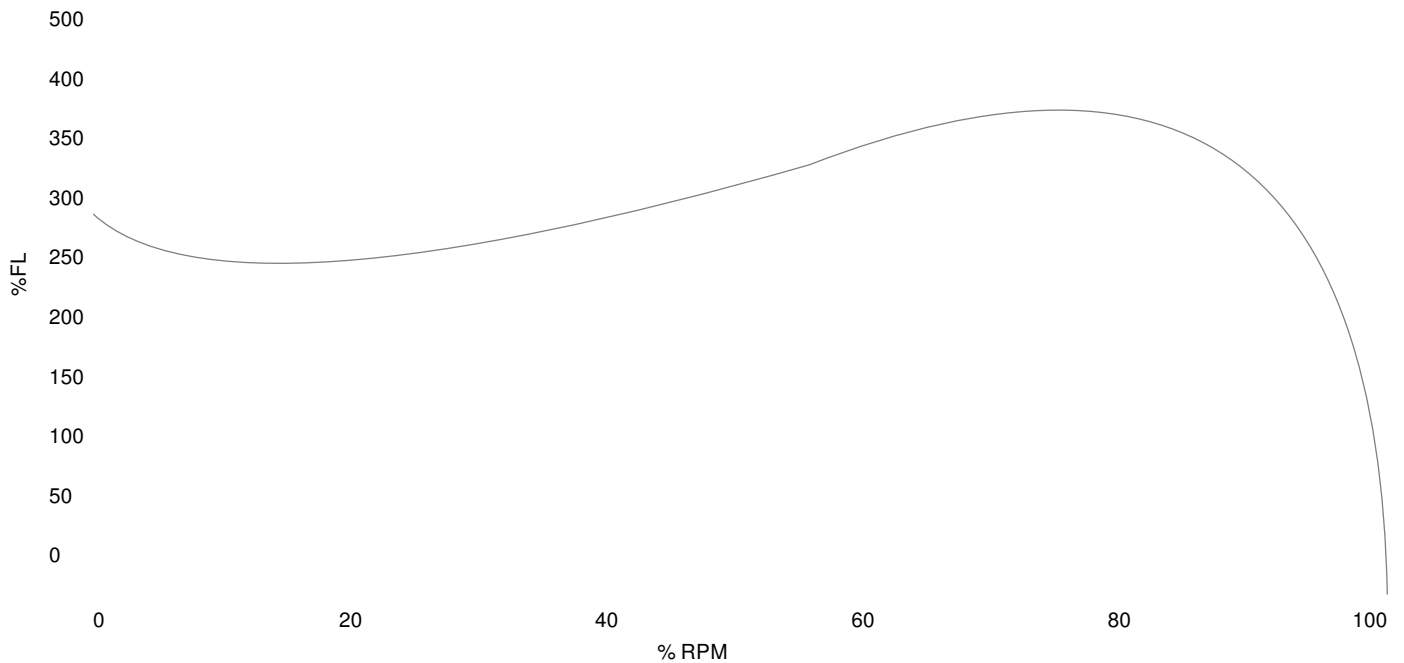

Performance Load Values, High Voltage, 60Hz

Torque Values	Torque lb-ft	% FLT	Performance Values	
Locked Rotor Torque	8.91226	294.0	Start Configuration	-
Pull-Up Torque	6.12339	202.0	Starting Current (A)	-
Breakdown Torque	10.0642	332.0	No-Load Current (A)	-
Full Load	3.03138	100.0	No-Load Power Factor	-

% Load	Horsepower	Current, Amps	Input power, Kilowatts	Speed, RPM	Efficiency	PF
0	-	1.29	-	-	-	-
25	0.5	1.37	489.13	3575.5	76.67	0.45
50	1.0	1.67	887.26	3554.1	84.53	0.67
75	1.5	2.08	1302.5	3529.7	86.37	0.79
100	2.0	2.58	1738.8	3502.4	86.27	0.85
125	2.5	3.14	2199.9	3472.1	85.23	0.88

Techtop Industries  
 2815 Colonnades Court  
 Peachtree Corners, GA 30071  
 Tel: 678-436-5540  
 E-Mail: info@techttopind.com