



NEMA Premium

NEMA

MOTOR MODEL:	BR3-CI-TF-254TC-4-BR-E-15
FACTORY TYPE:	TXC

Premium NEMA Cast Iron, TEFC

Non Sinusoidal (VFD) Output 15.0HP, 1760 RPM

Torque Speed (T-n) Curve

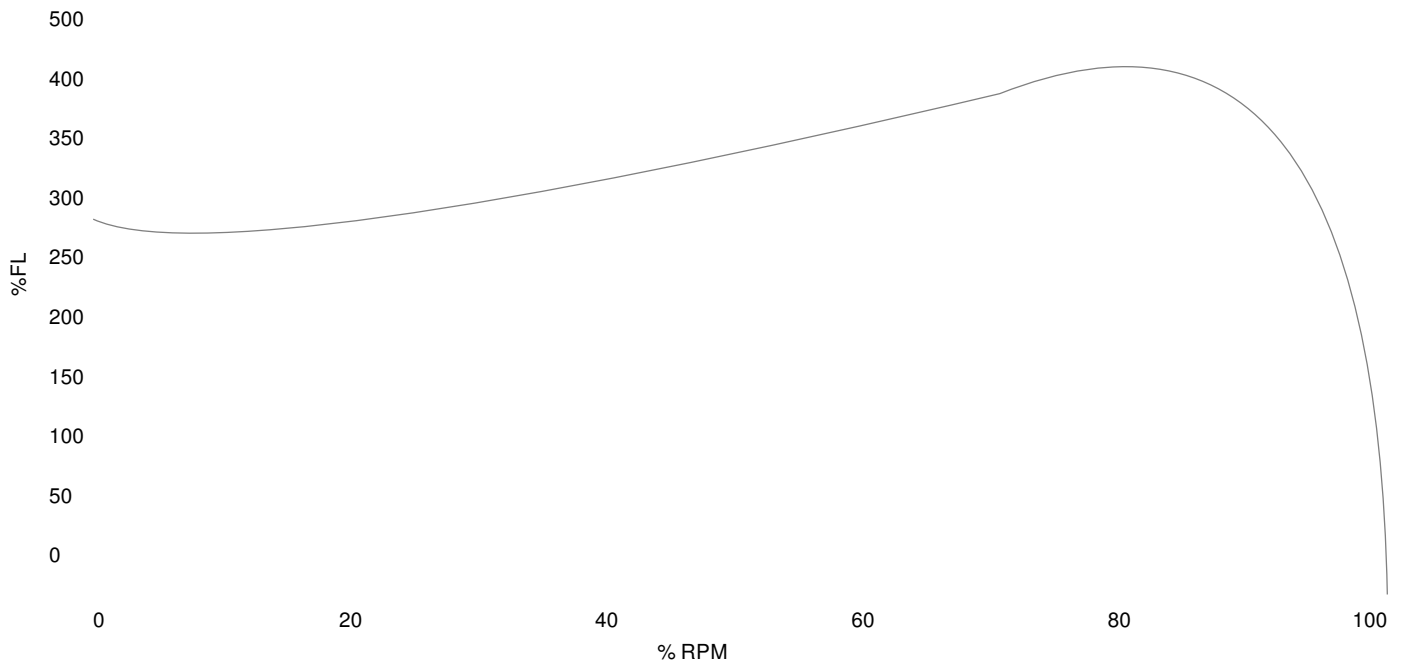

Performance Load Values, High Voltage, 60Hz

Torque Values	Torque lb-ft	% FLT	Performance Values
Locked Rotor Torque	130.197	290.0	Start Configuration
Pull-Up Torque	109.994	245.0	Starting Current (A)
Breakdown Torque	173.745	387.0	No-Load Current (A)
Full Load	44.8954	100.0	No-Load Power Factor

% Load	Horsepower	Current, Amps	Input power, Kilowatts	Speed, RPM	Efficiency	PF
0	-	8.37	-	-	-	-
25	3.75	9.23	3.28	1794.2	86.19	0.45
50	7.5	11.62	6.19	1788.5	91.29	0.67
75	11.25	14.7	9.16	1782.5	92.52	0.78
100	15.0	18.3	12.2	1776.1	92.63	0.84
125	18.75	22.25	15.31	1769.4	92.25	0.86

Techtop Industries
 2815 Colonnades Court
 Peachtree Corners, GA 30071
 Tel: 678-436-5540
 E-Mail: info@techttopind.com