



IE1

IEC

MOTOR MODEL:	BL3-AL-TF-63B35-4-B-D-.18
FACTORY TYPE:	TM

IE1 IEC Cast Aluminum, TEFC

ELECTRICAL DATA		
	60 Hz	50 Hz
Horsepower	0.18	0.18
Speed, RPM	1640	1300
Voltage	230/460	190/380
# Phase	3	
Full Load Amps	0.98/0.49	1.18/0.59
Power Factor	0.58	-
Nominal Efficiency	59.5	-
3/4 Load Efficiency	-	-
Service Factor	1.15	1.0
KVA Code	J	F
FL Amps. @ 208 V	0.99	-
LRC @ 60Hz HV	-	-
Start Capacitor	-	
Start Capacitor V	-	
Run Capacitor	-	
Run Capacitor V	-	
Number of Leads	9	
Connection	YY/Y	
Coil Resistance	-	
Date Code	-	
Load	Efficiency %	P.F.
50%	-	-
75%	-	-
100%	-	-
FULL LOAD TEMPERATURE RISE		
FL Temp Rise °C	-	-
3D Image Link		
Not available for this motor		

GENERAL DATA			
Frame Size	63B35		
Frame Enclosure	TEFC		
Mounting	B35		
Insulation Class	F		
Duty	Cont. / S1		
NEMA Design	-		
Frame Material	Cast Aluminum		
Ingress Protection	55		
Tropicalization	true		
Cable Entry	1-M16X1.5		
Feet Removable	true		
Double Drilled	-		
Paint Color	Graphite Gray		
Paint RAL	7024		
Weight lb	8.14		
MECHANICAL DATA			
DE Bearing	6201ZZ		
NDE Bearing	6201ZZ		
dB No-Load	-		
Rotor Wk ² , Lb-Ft ²	-		
Comp Ring (wavy washer)	-		
TORQUE VALUES		Torque lb-ft	% FLT
Locked Rotor Torque		-	-
Pull-Up Torque		-	-
Breakdown Torque		-	-
Full Load Torque		-	-
SITE CONDITIONS			
Ambient Temp °C		40	
Altitude Above Sea Level m		1000	

*This report valid for above Date Code and newer models, please contact Techtop for more info.



IE1

IEC

MOTOR MODEL:	BL3-AL-TF-63B35-4-B-D-.18
FACTORY TYPE:	TM

IE1 IEC Cast Aluminum, TEFC

Torque Speed (T-n) Curve

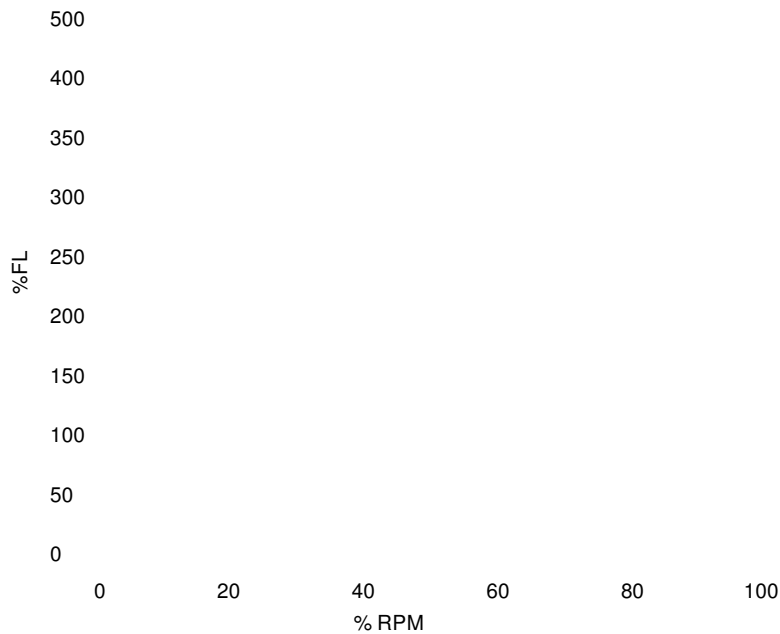

Performance Load Values, High Voltage, 60Hz

Torque Values	Torque lb-ft	% FLT	Performance Values
Locked Rotor Torque	-	-	Start Configuration
Pull-Up Torque	-	-	Starting Current (A)
Breakdown Torque	-	-	No-Load Current (A)
Full Load	-	-	No-Load Power Factor

% Load	Horsepower	Current, Amps	Input power, Kilowatts	Speed, RPM	Efficiency	PF
0	-	-	-	-	-	-
25	-	-	-	-	-	-
50	-	-	-	-	-	-
75	-	-	-	-	-	-
100	-	-	-	-	-	-
125	-	-	-	-	-	-